

PRODUCT DESCRIPTION

optibelt **VB** CLASSIC V-BELTS

DIN 2215 / ISO 4184

Structure/Properties

optibelt VB classic V-belts are manufactured using the same production processes as those for optibelt SK high performance wedge belts.

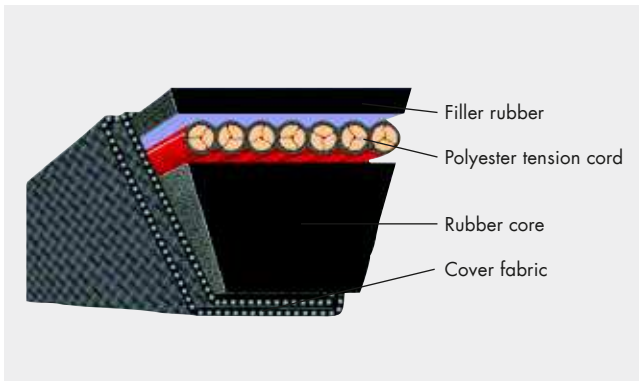

The components used are perfectly suited to the power ratings P_N . These values are far above those given by DIN 2218. Thus the operational safety in existing drives is increased and overloading is avoided.

- optibelt VB classic V-belts have a height-width ratio of 1:1.6.
- The maximum belt speed $v_{max} = 30$ m/s should not be exceeded.
- The allowed flexibility rate is far below that of wedge belts. It is $f_{B, max} = 80$ s⁻¹.

Application areas

optibelt VB classic V-belts are mainly employed as replacement parts for industrial drives. For new drives, the use of high performance wedge belts is almost always recommended due to reasons of space and cost. However, special drives such as V-flat drives can often only be operated with classic V-belts. In special constructions, optibelt VB classic V-belts tackle difficult drives in the gardening sector and in agricultural machinery.

For these applications special belt constructions and calculation methods are required which are not included in this manual. In these cases we ask you to give us the according drive data.

Standardisation/Dimensions

optibelt VB classic V-belts in the profiles Y/6, Z/10, A/13, B/17, C/22, D/32 and E/40 are standardised according to DIN 2215 and ISO 4184.

Further, non-standardised ISO profiles 5, 8, 20 and 25 are available. These profiles should however not be used due to reasons of exchangeability and rationalisation.

The ISO standard 4184 specifies the datum length for measuring the belt length. The former belt designation of the inside length L_i is replaced by the datum length L_d . For the conversion factors from pitch to inside length, please see page 161.

Note: Electrically conductive according to ISO 1813.

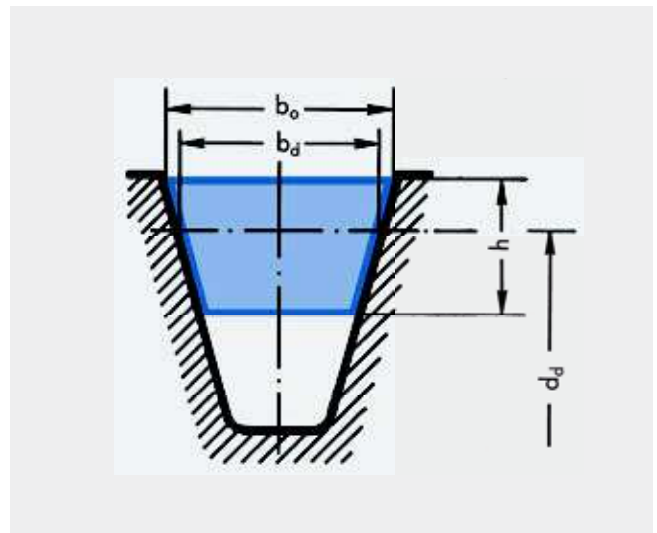

Table 7

Profile	DIN 2215	(5)	6	(8)	10	13	17	(20)	22	(25)	32	40
	ISO 4184	-	Y	-	Z	A	B	-	C	-	D	E
Belt top width	$b_o \approx$	5	6	8	10	13	17	20	22	25	32	40
Datum width	b_d	4.2	5.3	6.7	8.5	11	14	17	19	21	27	32
Belt height	$h \approx$	3	4	5	6	8	11	12.5	14	16	20	25
Recommended minimum pulley outside diameter	$d_{d, min}$	20	28	40	50	75	125	160	200	250	355	500
Belt weight (kg/m)	\approx	0.018	0.026	0.042	0.064	0.109	0.190	0.266	0.324	0.420	0.690	0.958
Flex rate (s ⁻¹)	$f_{B, max} \approx$						80					
Belt speed (m/s)	$v_{max} \approx$						30					

STANDARD RANGE

optibelt **VB** CLASSIC V-BELTS

DIN 2215 / ISO 4184



5



Y/6



8



Z/10

Profile 5*		Profile Y/6*		Profile 8		Profile Z/10								
Datum length ISO L _d [mm]	Inside length L _i [mm]	Datum length ISO L _d [mm]	Inside length L _i [mm]	Datum length ISO L _d [mm]	Inside length L _i [mm]	Belt no.	Datum length ISO L _d [mm]	Inside length L _i [mm]	Belt no.	Datum length ISO L _d [mm]	Inside length L _i [mm]	Belt no.	Datum length ISO L _d [mm]	Inside length L _i [mm]
200	190	295	280	335*	315*	Z 11	312*	290*	Z 38½	997	975	Z 68	1747	1725
239	229	315	300	375*	355*	Z 12½	337*	315*	Z 39	1022	1000	Z 69	1772	1750
270	260	350	335	420*	400*	Z 14	397*	375*	Z 40	1038	1016	Z 70	1797	1775
290	280	415	400	445*	425*	Z 15	422*	400*	Z 40½	1052	1030	Z 71	1822	1800
310	300	440	425	470*	450*	Z 16	447*	425*	Z 41	1063	1041	Z 73	1872	1850
325	315	465	450	495*	475*	Z 17	472*	450*	Z 41½	1072	1050	Z 75	1922	1900
332	322	515	500	510*	490*	Z 18	497*	475*	Z 42	1082	1060	Z 78	1997	1975
345	335	555	540	550*	530*	Z 19	502*	480*	Z 43	1102	1080	Z 79	2022	2000
385	375	615	600	580*	560*	Z 19¼	522*	500*	Z 43¼	1122	1100	Z 83½	2142	2120
435	425	865	850	595*	575*	Z 20	537*	515*	Z 44	1142	1120	Z 88	2262	2240
485	475			620*	600*	Z 20½	547*	525*	Z 45	1172	1150	Z 93	2382	2360
510	500			650*	630*	Z 21	552*	530*	Z 46	1187	1165	Z 98	2522	2500
540	530			690*	670*	Z 21¼	562*	540*	Z 46½	1202	1180			
564	554			720*	700*	Z 22	582*	560*	Z 47	1216	1194			
610	600			730*	710*	Z 23	597	575	Z 48	1237	1215			
				770*	750*	Z 24	622	600	Z 48½	1247	1225			
				795*	775*	Z 25	652	630	Z 49	1272	1250			
				820*	800*	Z 26	672	650	Z 50	1292	1270			
				845	825	Z 27	692	670	Z 51	1317	1295			
				870	850	Z 27½	722	700	Z 52	1342	1320			
				895	875	Z 28	732	710	Z 53	1368	1346			
				920	900	Z 28½	747	725	Z 54	1393	1371			
				970	950	Z 29	752	730	Z 55	1422	1400			
				1020	1000	Z 29½	772	750	Z 56	1444	1422			
				1040	1020	Z 30	787	765	Z 57	1472	1450			
				1070	1050	Z 31	797	775	Z 58	1497	1475			
				1095	1075	Z 31½	822	800	Z 59	1522	1500			
				1140	1120	Z 32	842	820	Z 60	1546	1524			
				1220	1200	Z 33	847	825	Z 61	1572	1550			
				1270	1250	Z 33½	872	850	Z 62	1597	1575			
						Z 34	887	865	Z 63	1622	1600			
						Z 35	897	875	Z 64	1648	1626			
						Z 36	922	900	Z 65	1673	1651			
						Z 37	947	925	Z 66	1697	1675			
						Z 38	972	950	Z 67	1722	1700			
Further sizes on request Weight: ≈ 0.018 kg/m	Further sizes on request Weight: ≈ 0.026 kg/m	Weight: ≈ 0.042 kg/m	Maximum production length: 4500 mm Minimum order quantity: Over 1800 mm = 20 pieces for non-standard length ranges 60 pieces for special constructions Weight: ≈ 0.064 kg/m											

Datum length L_d ≙ Pitch length L_w/L_p * Raw edge, moulded cogged V-belts Further sizes on request

Lengths in **bold** type are in S=C plus (SetConstant).